

PRINCIPLES OF ELECTRICAL ENGINEERING

(Common to ECE, EIE, E.Con.E & ECC)

Time: 3 hours

Max. Marks: 70

Answer any FIVE questions
All questions carry equal marks

- 1 Find initial conditions for voltage across capacitor, the currents i_1 , i_2 and the derivatives for the circuit shown in fig. below. Take $R_1=10\ \Omega$.

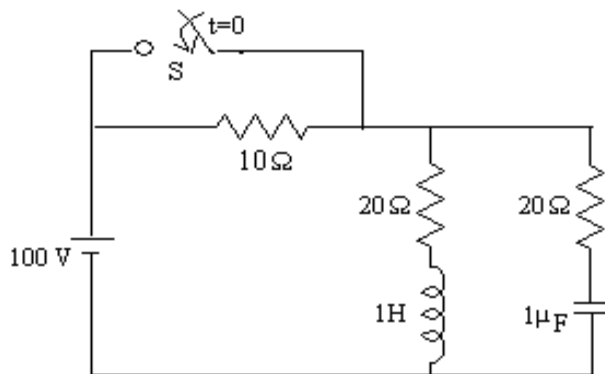

- 2 (a) Derive the relation between 'Y' and ABCD parameters.
(b) A two port network has the following parameters: $Z_{11} = 4\ \Omega$, $Z_{12} = 1\ \Omega$, $Z_{21} = 3\ \Omega$ and $Z_{22} = 3\ \Omega$. Calculate transmission parameters.
- 3 Design a constant-K band rejection filter having the cut off frequencies $f_1 = 1250\ \text{Hz}$ and $f_2 = 6000\ \text{Hz}$ and a characteristic impedance $Z_0 = 500\ \Omega$.
- 4 (a) What is an attenuator? Derive the design equations for Bridged T-type attenuator.
(b) Design a π -type attenuator to give 20 dB attenuation and to have a characteristic impedance of $50\ \Omega$.
- 5 Explain the characteristics of DC generator in detail.
- 6 What is the aim of Swinburne's test? Explain the procedure with a neat circuit diagram.
- 7 A single phase transformer working at 0.6 power factor has an efficiency of 75% at both half load, at full load of 2 kW. Determine the efficiency at 90% of full load.
- 8 (a) Explain the principle of operation of AC servo motor.
(b) Explain the characteristics of capacitor motor.
